

# MAGIS

Riace by Ronan & Erwan Bouroullec



# Ronan & Erwan Bouroullec



## Profile:

Ronan Bouroullec (born in 1971) and Erwan Bouroullec (born in 1976) have been working together for more than twenty years now. Their collaboration is a permanent dialogue, nourished by their distinct personalities and a shared notion of diligence, with the intention to achieve greater balance and refinement.

In 1997, they presented their Disintegrated Kitchen at the Salon du Meuble in Paris, where it was spotted by Giulio Cappellini, who gave them their first industrial design commissions. The Bouroullecs have been working with Magis since 2004, designing three complete furniture collections – Striped, Steelwood and Officina – as well as additional projects such as Pila chair, Pilo table, Central and Tambour tables. These days, Ronan and Erwan Bouroullec design for numerous manufacturers, including Magis, Vitra, Kvadrat, Kartell, Established and Sons, Ligne Roset, Axor, Alessi, Issey Miyake, Cappellini, Mattiazzi, Flos, Mutina,

Hay and more recently Glas Italia and Iittala. They also continue to carry out their own experimental activity which is essential to the development of their work at Galerie kreò, Paris, where four exhibitions of their designs were held between 2001 and 2012. They also embark on occasional architectural projects.

Voted Designers of the Year at the Salon du Meuble in 2002, their other awards include the Compasso d'Oro won in 2011 for the Steelwood chair they designed for Magis. Several exhibitions have been devoted to their work.

In 2012, Phaidon Press published *Works*, a comprehensive monographic book about Ronan and Erwan Bouroullec. Previously, two other monographs had been published about the Bouroullec brothers' design work: *Ronan et Erwan Bouroullec – Catalogue de Raison* (Paris: Images Modernes / kreò, 2002) and *Ronan et Erwan Bouroullec* (Paris: Phaidon Press, 2003).







# Design and

Ronan & Erwan Bouroullec once again create a new sofa playing on contrasting lines and volumes.

Riace, an ode to the beauty of the town with its famous Warrior statues, is a short-circuit of dynamic rigour. Equally sculptural and sinuous, the Riace sofa has a slender white bronze frame supporting a seemingly-suspended, wide upholstered seat and backrest. It comes in one size and shape only, while the fabric covers can be changed to suit different furnishing needs. Riace fits perfectly well in both residential and contract environments.

Once again, an impeccable balance between seriousness and lightness defines the style of the two designers, creating an instantly familiar, exciting and vibrant atmosphere. To impress, but without excess.



# Engineering





“The dynamic rigour is defined by the slender white bronze frame that



holds, as if suspended, a wide upholstered seat and backrest.”







# Information



# Product

4-seater sofa.

Frame in tumbled white bronze. Seat and backrest cushions padded with shaped fire-resistant polyurethane foam (rating 1 IM) and mattress with individually pocketed springs. Covering in removable fabric.





SOFA



Frame /  
White bronze  
White bronze

Fabric /  
Fabric cat.1  
Fabric cat.2

Materials /

Frame in white bronze /



white  
bronze

Fabric cat 1 /

Torri Lana Rella



003 047 041

Fabric cat 2 /

Kvadrat Vidar

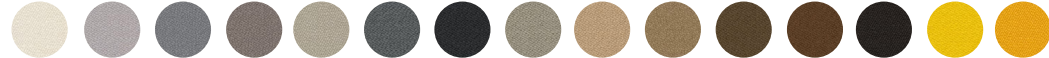

0106 0123 0133 0143 0146 0152 0182 0222 0323 0333 0353 0363 0386 0443 0456



0472 0526 0542 0554 0556 0582 0622 0633 0653 0656 0676 0693 0723 0743 0772

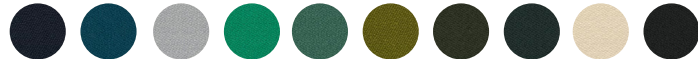

0786 0872 0913 0932 0943 0956 0972 1062 1511 1880

Kvadrat Alle



134 194 564 784 984

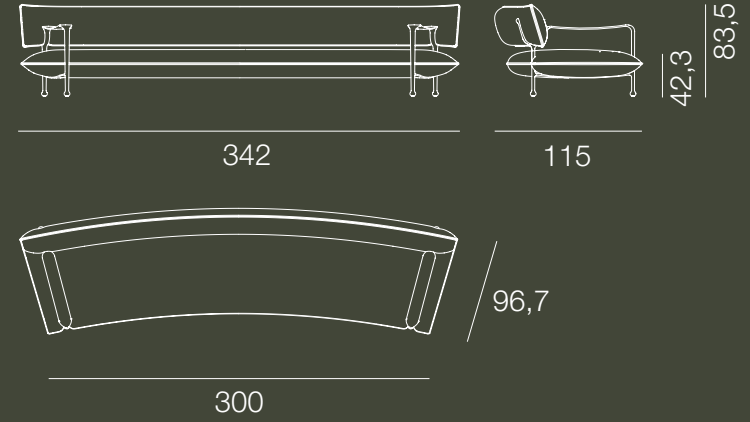



MAGIS



